



OMAHA STANDARD SERVICE BODIES ORDER MENU



REFERENCE NUMBER: _____

CUSTOMER: _____

DATE: _____

CHASSIS: MAKE: _____ MOD: _____ YEAR: _____ CA: _____

BODY LAYOUT

80" SERVICE BODY OR 96" SERVICE BODY OR 108" SERVICE BODY OR 132" SERVICE BODY OR 156" SERVICE BODY 168" SERVICE BODY

FORD CHEVY

STANDARD TOP OPEN

STANDARD DEEP

STANDARD LOW PROFILE

38 48 54 64

ELIMINATE WHEELBOX IF APPLICABLE
CUSTOMER RESPONSIBLE FOR PROPER TIRE CLEARANCE

STREETSIDE OR CURBSIDE

"V" CONFIGURATION "H" CONFIGURATION

LATCH OPTIONS

ROTARY LATCH, STAINLESS
 FINISH, OMAHA LOGO

1-POINT "T" LATCH
 STAINLESS FINISH

3-POINT "T" LATCH
 STAINLESS FINISH

NOTE: 3 POINT "T" LATCH IS STANDARD EQUIPMENT ON FRONT RAISED COMPARTMENT DOORS

TAILGATE OPTIONS

LOGO ONLY AVAILABLE ON 48/54 MODELS

ROTARY SLAM TAILGATE W/LOGO
 ROTARY SLAM, NO LOGO

COMPARTMENT OPTIONS

DIVIDER TRAY DIVIDERS (20) FURNISHED STD. SHELF

BOOK RACK 9-DRAWER PARTS CABINET 12-DRAWER PARTS CABINET 18-DRAWER PARTS CABINET

SLIDE OUT TRAYS

FRONT COMPARTMENT		INTERMEDIATE COMPARTMENT (132 ONLY)		REAR COMPARTMENT	
STREETSIDE	CURBSIDE	STREETSIDE	CURBSIDE	STREETSIDE	CURBSIDE
<input type="checkbox"/>	<input type="checkbox"/>	<input type="checkbox"/>	<input type="checkbox"/>	<input type="checkbox"/>	<input type="checkbox"/>
DIVIDER TRAYS, (2) FURNISHED STD.		DIVIDER TRAYS		SHELF, (1) FURNISHED STD.	
<input type="checkbox"/>	<input type="checkbox"/>	<input type="checkbox"/>	<input type="checkbox"/>	<input type="checkbox"/>	<input type="checkbox"/>
EXTRA DIVIDER TRAYS		SHELVES		<input type="checkbox"/>	<input type="checkbox"/>
<input type="checkbox"/>	<input type="checkbox"/>	<input type="checkbox"/>	<input type="checkbox"/>	<input type="checkbox"/>	<input type="checkbox"/>
SHELVES		SINGLE SLIDE OUT TRAYS		<input type="checkbox"/>	<input type="checkbox"/>
<input type="checkbox"/>	<input type="checkbox"/>	<input type="checkbox"/>	<input type="checkbox"/>	<input type="checkbox"/>	<input type="checkbox"/>
SINGLE SLIDE OUT TRAYS		NESTED SLIDE OUT TRAYS		<input type="checkbox"/>	<input type="checkbox"/>
<input type="checkbox"/>	<input type="checkbox"/>	<input type="checkbox"/>	<input type="checkbox"/>	<input type="checkbox"/>	<input type="checkbox"/>
NESTED SLIDE OUT TRAYS		PARTS CABINET		<input type="checkbox"/>	<input type="checkbox"/>
<input type="checkbox"/>	<input type="checkbox"/>	<input type="checkbox"/>	<input type="checkbox"/>	<input type="checkbox"/>	<input type="checkbox"/>
DUAL GAS BOTTLE HOLDER		9 DRAWER		<input type="checkbox"/>	<input type="checkbox"/>
<input type="checkbox"/>	<input type="checkbox"/>	12 DRAWER		<input type="checkbox"/>	<input type="checkbox"/>
DROP WELL FOR BOTTLES		18 DRAWER		<input type="checkbox"/>	<input type="checkbox"/>
<input type="checkbox"/>	<input type="checkbox"/>	WATER CASK SHELF		<input type="checkbox"/>	<input type="checkbox"/>
VENTS IN DOOR/COMPARTMENT					



OMAHA STANDARD SERVICE BODIES ORDER MENU-CONTINUED



BUMPER OPTIONS

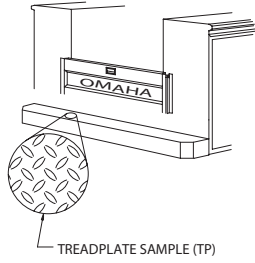

TREADPLATE SAMPLE (TP)

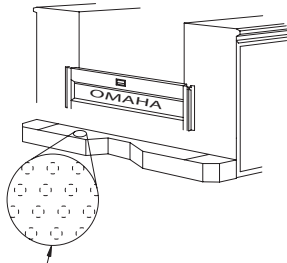

GRIP PUNCH SAMPLE (GPR)

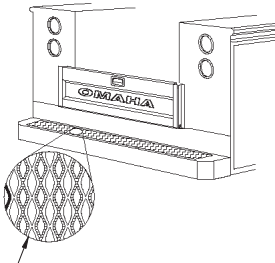

GRIP STRUT SAMPLE (GSR-BPI)

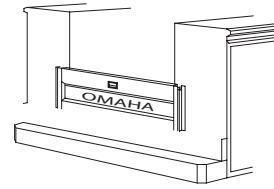

GRIP PUNCH LIGHTED (BPL)

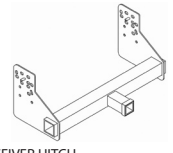

RECEIVER HITCH

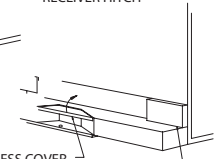

HINGED RECESS COVER

ADD ON BUMPER LIGHT KIT

BUMPER WIDTH

- 78 1/2" WIDE - MODEL 80
- 88 1/2" WIDE - MODEL 90
- 94 1/2" WIDE - MODEL 96

BUMPER MATERIAL

- TREADPLATE - PREFIX TP
- GRIP PUNCH - PREFIX GP
- GRIP STRUT - PREFIX GS

BUMPER FEATURES

- STRAIGHT - NO RECESS
- RECESSED - ADD "R" TO PREFIX
- RECESSED WITH BALL PLATE - SUFFIX GPI
- LIGHTED - SUFFIX BPL (INTEGRAL TO BUMPER ASSY)

BUMPER OPTIONS

- MODEL NO. "BLP-1" LIGHT KIT UNDER 80" WIDE (ADD ON)
- MODEL NO. "BLP-2" LIGHT KIT OVER 80" WIDE (ADD ON)
- SUFFIX "HRC" HINGED COVER OVER RECESS

HI ROOF

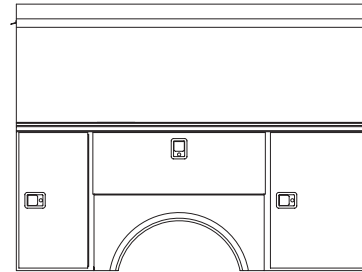
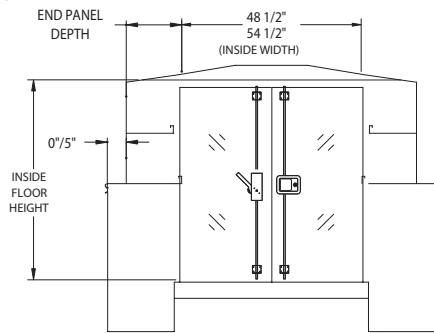

INSIDE FLOOR HEIGHT

- 54" HIGH - MODEL HR54
- 60" HIGH - MODEL HR60
- 72" HIGH - MODEL HR72

FLOOR WIDTH - MUST MATCH BODY

- 48 1/2" WIDE
- 54 1/2" WIDE

END PANEL DEPTH

- 10" DEEP - STD. ONLY (5" OFFSET)
- 15" DEEP - STD (NO OFFSET) OR DEEP (5" OFFSET)
- 20" DEEP - DEEP (NO OFFSET)

STANDARD FEATURES

- 14 X 30 WINDOW IN FRONT BULKHEAD
- DUAL REAR DOORS INSTALLED
- 12 X 15 GLASS IN DOOR (TOP)

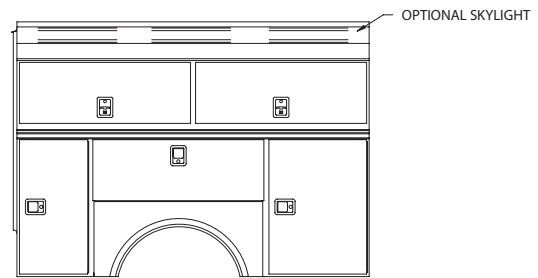
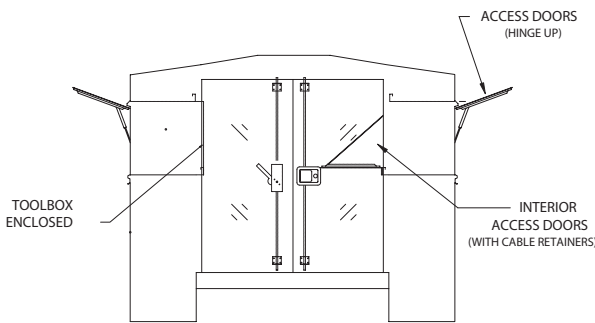

HI ROOF OPTIONS

- (6) 5 X 27 SKYLIGHT WINDOWS, (3) EACH SIDE
- 14 X 30 SLIDING WINDOW IN FRONT BULKHEAD

WINDOW GUARDS OVER WINDOWS

- BULKHEAD GLASS
- REAR DOOR GLASS

DELETE WINDOWS

- BULKHEAD GLASS
- REAR DOOR GLASS

DELETE REAR DOORS

- ONE DOME LIGHT WITH REAR SWITCH
- TWO DOME LIGHTS WITH REAR SWITCH
- INSTALLED
- LOOSE
- INSTALLED
- LOOSE

ADDITIONAL HI ROOF OPTIONS

STREETSIDE

-
-
-
-
-

CURBSIDE

- (1) EXTRA SHELF IN HI ROOF
- EXTERIOR ACCESS DOORS (LIFT UP) (FULL WIDTH END PANELS ONLY)
- INTERIOR ACCESS DOORS (DROP DOWN)
- TOOLBOX CLOSURE PANELS
- ROOF VENT



OMAHA STANDARD SERVICE BODIES ORDER MENU-CONTINUED



LOW SLIDING ROOF

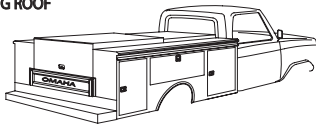

LOW SLIDING ROOF

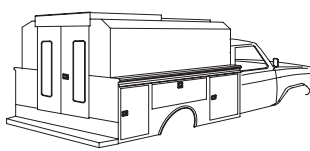

HI ROOF WITH LOW SLIDING ROOF IN LIEU OF FIXED ROOF

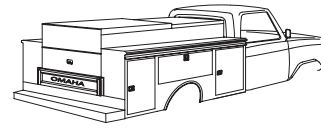

RAISED LOW SLIDING ROOF
RAISED _____" HIGH

DOOR OPTIONS

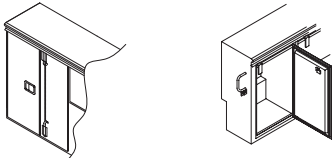

DUAL VERTICAL DOORS
 PULL TYPE MASTER LOCKING
 ROTARY MASTER LOCKING

THROUGH COMPARTMENT OPTIONS

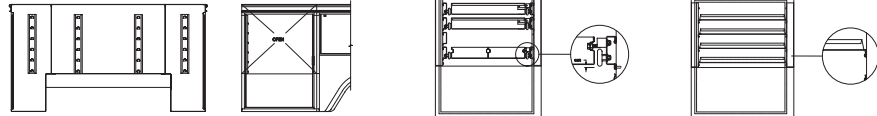

THROUGH COMPARTMENT

3/4 WIDTH - OPEN STREETSIDE
 3/4 WIDTH - OPEN CURBSIDE
 FULL WIDTH - OPEN BOTH SIDES

THROUGH COMPT. TRAYS
MAX. 48 STD. 91 LP

THROUGH COMPT. SHELVES
MAX. 48 STD. 91 LP

GAS BOTTLE OPTIONS

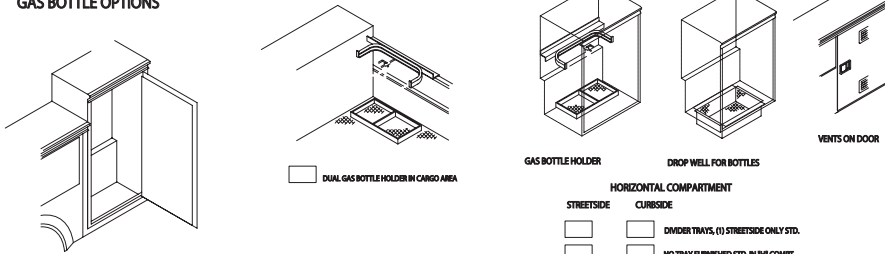

FRONT RAISED COMPARTMENT

50" HIGH
 60" HIGH
 66" HIGH

DUAL GAS BOTTLE HOLDER IN CARGO AREA

GAS BOTTLE HOLDER

DROP WELL FOR BOTTLES

VENTS ON DOOR

HORIZONTAL COMPARTMENT

STREETSIDE	CURBSIDE
<input type="checkbox"/>	<input type="checkbox"/> DIVIDER TRAYS, (1) STREETSIDE ONLY STD.
<input type="checkbox"/>	<input type="checkbox"/> NO TRAY FURNISHED STD. IN 1/4 COMPT.
<input type="checkbox"/>	<input type="checkbox"/> EXTRA DIVIDER TRAYS
<input type="checkbox"/>	<input type="checkbox"/> SHELVES
<input type="checkbox"/>	<input type="checkbox"/> SINGLE SLIDE OUT TRAYS
<input type="checkbox"/>	<input type="checkbox"/> NESTED SLIDE OUT TRAYS
<input type="checkbox"/>	<input type="checkbox"/> ROCK RACK
<input type="checkbox"/>	<input type="checkbox"/> PARTS CABINET

GRIP PUNCH OVERLAY OPTIONS

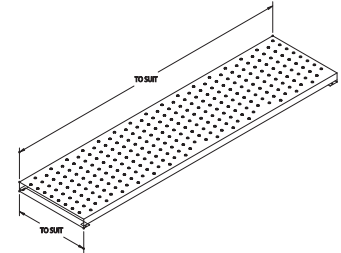

GRIP PUNCH WALK WAY - SUPPLIED LOOSE

LOCATION _____

TREADPLATE OVERLAY OPTIONS

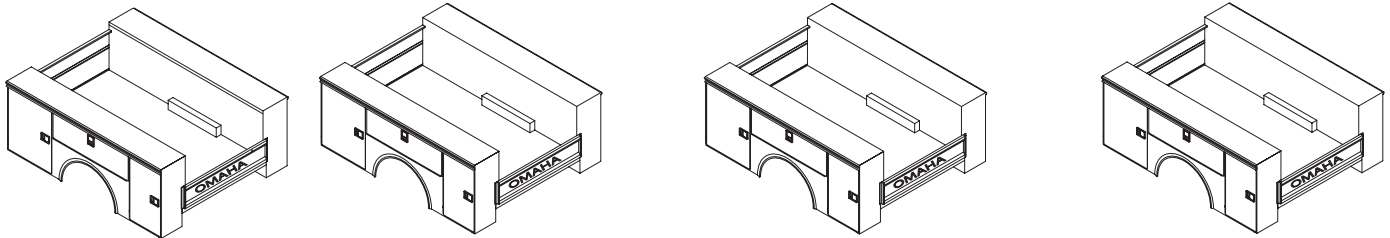

12 GA. TREADPLATE STEEL OVERLAY ON COMPARTMENT TOPS
FURNISHED STANDARD WITH 6,000# CRANE REINFORCING

STREETSIDE
 CURBSIDE

.10 TREADPLATE ALUMINUM OVERLAY ON COMPARTMENT TOPS
(SUPPLIED LOOSE)

STREETSIDE
 CURBSIDE

12 GA. TREADPLATE STEEL OVERLAY ON COMPARTMENT BACKS
FURNISHED STANDARD WITH 6,000# CRANE REINFORCING

STREETSIDE
 CURBSIDE

12 GA. TREADPLATE STEEL OVERLAY INSIDE FRONT BULL-HEAD
FURNISHED STANDARD WITH 6,000# CRANE REINFORCING

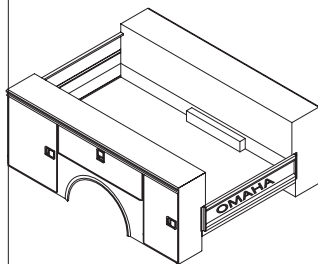
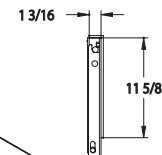

6" HIGH SCUFF PLATES IN LOAD SPACE

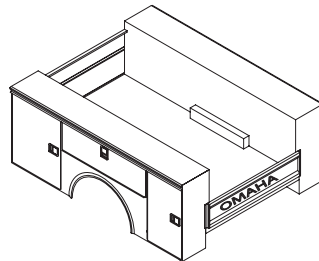

12 GA. TREADPLATE STEEL OVERLAY ON REAR END PANELS
FURNISHED STANDARD WITH 6,000# CRANE REINFORCING

STREETSIDE
 CURBSIDE

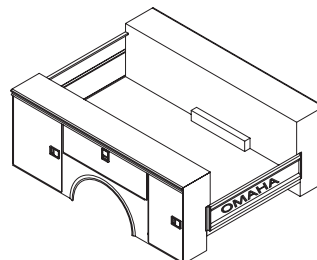

12 GA. TREADPLATE STEEL OVERLAY INSIDE TAILGATE

.10 TREADPLATE ALUMINUM OVERLAY ON ROCK GUARDS
(SUPPLIED LOOSE)
INCLUDES (2) PIECES



OMAHA STANDARD SERVICE BODIES ORDER MENU-CONTINUED



CRANE REINFORCEMENT

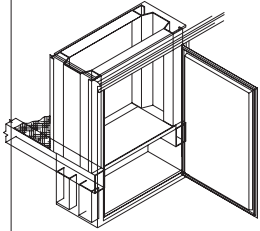

- 2K CRANE REINFORCING (8000 FT LBS)
- 4K CRANE REINFORCING (16000 FT LBS)
- 6K CRANE REINFORCING (38000 FT LBS)

AVAILABLE BOTH CURBSIDE AND STREETSIDE

HOT STICK OPTIONS

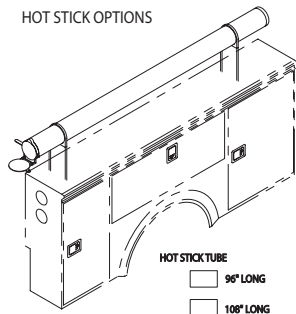

- HOT STICK TUBE
- 96" LONG
 - 108" LONG

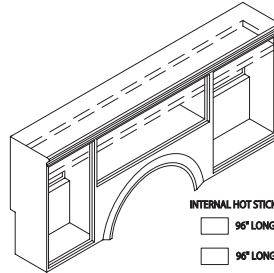

INTERNAL HOT STICK SHELF

- 96" LONG
- 96" LONG WITH WOOD LINER
- 99" LONG (132 BODY)
- 99" LONG (132 BODY) WITH WOOD LINER
- 108" LONG
- 108" LONG WITH WOOD LINER
- INCLUDE 7' X 10" REAR ACCESS DOOR

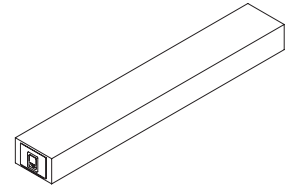

EXTERNAL HOT STICK BOX, 15" W X 9" H

- 96" LONG
- 96" LONG WITH WOOD LINER
- 108" LONG
- 108" LONG WITH WOOD LINER

LADDER RACK OPTIONS

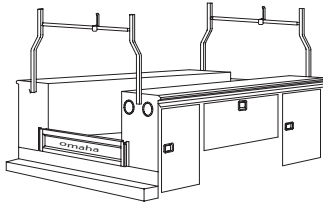

LR-1 OVERHEAD LADDER RACK

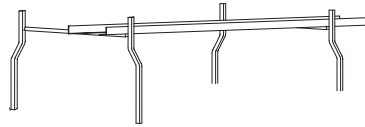

LR-2 LADDER RAILS FOR OVERHEAD LADDER RACK

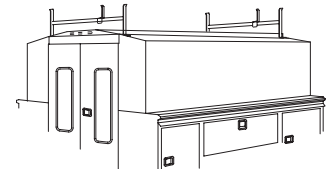

LR-7 HI ROOF/OSV OVERHEAD LADDER RACK

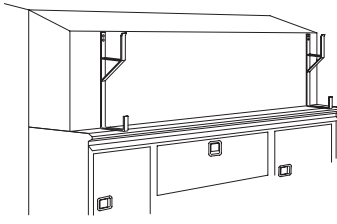

LR-4S HI ROOF SIDE MOUNT LADDER RACK

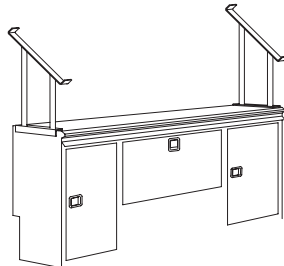

LR-3 SERVICE BODY TOP MOUNT LADDER RACK, SLOPED

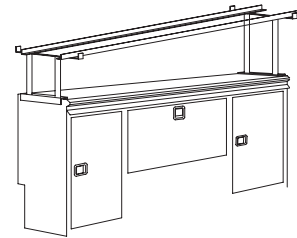

LR-5 SERVICE BODY TOP MOUNT LADDER RACK, TAPERED

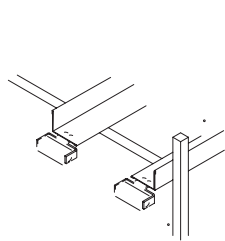

LR-1 LADDER ROLLERS

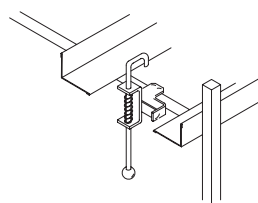

LR-3 SPRING LOADED LADDER CLAMP

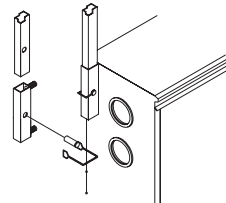

LR-4 QUICK REMOVAL BRACKETS

CONE HOLDER



CONE HOLDER

PIPE RACK

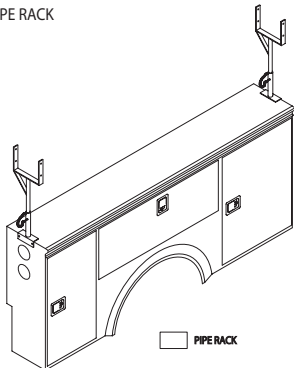

PIPE RACK

VICE BRACKET OPTIONS

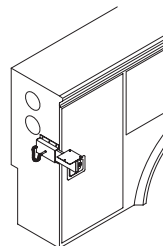

PIPE VICE RACK WITH FRONT SUPPORT

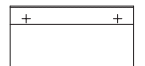
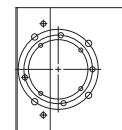
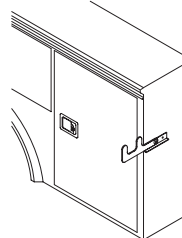

MECHANIC'S VICE BRACKET



OMAHA STANDARD SERVICE BODIES ORDER MENU-CONTINUED



LIGHT KIT OPTIONS

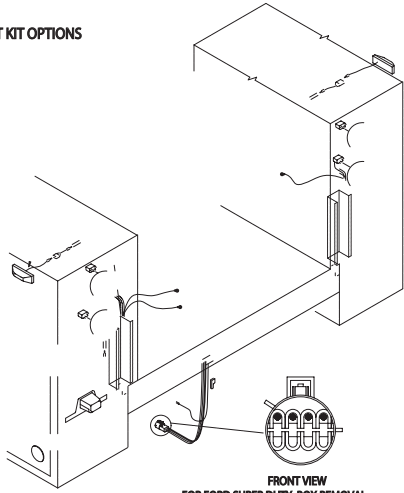

- XBL-1 LIGHT KIT
- XBL-1 LED LIGHT KIT

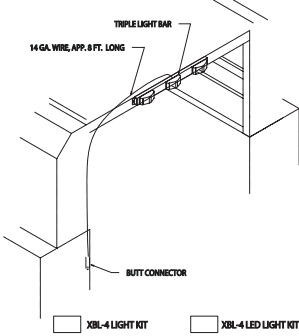

- XBL-4 LIGHT KIT
- XBL-4 LED LIGHT KIT

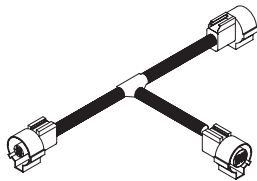

- XBL-5 FORD SUPER DUTY CHASSIS CAB ADAPTER (FOR 60, 64, 108 AND 120 CHASSIS CABS ONLY)

NO DRAWING AVAILABLE

- XBL-10 OSV AND HI ROOF TRIPLE LIGHTS (KIT IS FOR RED REAR AND AMBER FRONT)

NO DRAWING AVAILABLE

- XBL-14 (2004 FORD CUT AWAY CHASSIS) (RETURN FLASHERS TO NORMAL RATE)

NO DRAWING AVAILABLE

- XBL-6 FORD SUPER DUTY CHASSIS CAB ADAPTER (FOR 40 AND 56" CA PICK UP TRUCKS ONLY)

NO DRAWING AVAILABLE

- XBL-8 (LED LIGHT KIT & FORD TRUCKS ONLY) (RETURN FLASHERS TO NORMAL RATE)

NO DRAWING AVAILABLE

- XBL-9 LED (INCLUDES LED BACK UP LIGHTS & ADAPTER) (STD XBL-1 LED SUPPLIED W/INCANDESCENT LIGHTS)

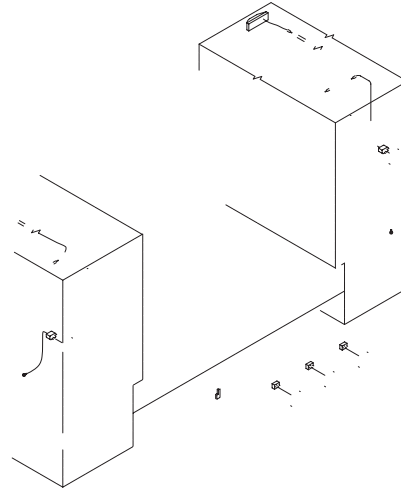

- XBL-2 LIGHT KIT
- XBL-2 LED LIGHT KIT

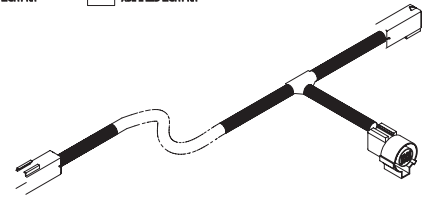

- XBL-3 DODGE CHASSIS CAB ADAPTER

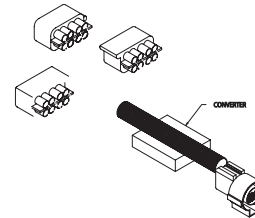

- XBL-7 1999 AND NEWER CHEVY/GMC BOX REMOVAL ADAPTER

COMPARTMENT LIGHTS AVAILABLE

- _____ DOME LIGHT
- _____ STRIP LIGHTING

SHOVEL BOX

56

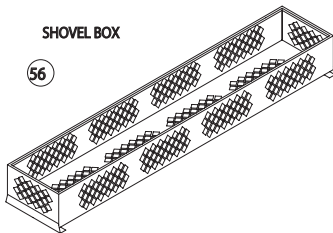

- SHOVEL BOX - SUPPLIED LOOSE
75" LONG X 15" WIDE X 8" HIGH

TIRE CARRIER OPTIONS

57

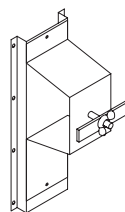

- TIRE CARRIER - STANDARD
- NOT INSTALLED
- INSTALLED - LOCATION

58

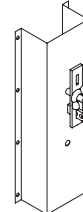

- TIRE CARRIER - WITH LOCK
- NOT INSTALLED
- INSTALLED - LOCATION

59

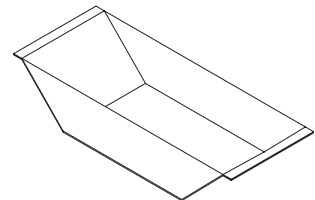

- RECESSED WELL
- NOT INSTALLED
- INSTALLED - LOCATION



OMAHA STANDARD SERVICE BODIES ORDER MENU-CONTINUED



TIE DOWN OPTIONS



2,000LB. TIE DOWNS

- NOT INSTALLED - QUANTITY _____
- INSTALLED - QUANTITY _____
- LOCATION _____

6,000LB. TIE DOWNS

- NOT INSTALLED - QUANTITY _____
- INSTALLED - QUANTITY _____
- LOCATION _____

MATERIAL HOOK OPTIONS



SLIDING MATERIAL HOOKS

- NOT INSTALLED - QUANTITY _____
- INSTALLED - QUANTITY _____
- LOCATION _____

FIXED MATERIAL HOOKS

- NOT INSTALLED - QUANTITY _____
- INSTALLED - QUANTITY _____
- LOCATION _____

SPRING MOUNT KIT

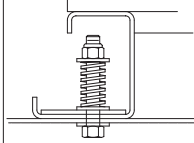

OPTIONAL MOUNTING KITS

- 32-80051 SPRING MOUNT KIT
- 32-87162 (FORD FOR BODY LENGTH 108" FOR 60" CA)
- 32-87163 (FORD FOR BODY LENGTH 132" FOR 84" CA)
- 32-87170 (DODGE WHEN ORDER WITH BODY FOR 108" FOR 60" CA)
- 32-87164 (DODGE WHEN ORDER WITH BODY FOR 132" FOR 84" CA)
- 32-87164 (DODGE WHEN ORDERED SEPARATE FOR 108" FOR 60" CA)
- 32-87165 (DODGE WHEN ORDERED SEPARATE FOR 132" FOR 84" CA)

ALUMINUM FUEL FILL CUP



- ALUMINUM FUEL FILL CUP - SUPPLIED LOOSE

ACCESS STEP OPTIONS

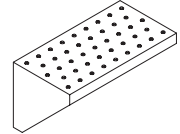
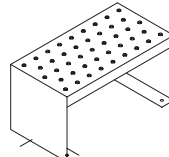
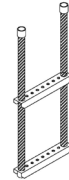
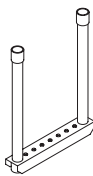

- CABLE STIRRUP STEP - SUPPLIED LOOSE
- SINGLE QUANTITY _____
- DOUBLE QUANTITY _____

- ACCESS STEP, COMPT. TOP - SUPPLIED LOOSE
- QUANTITY _____

- ACCESS STEP, COMPT. BACK - SUPPLIED LOOSE
- QUANTITY _____

GRIP PUNCH ACCESS STEP

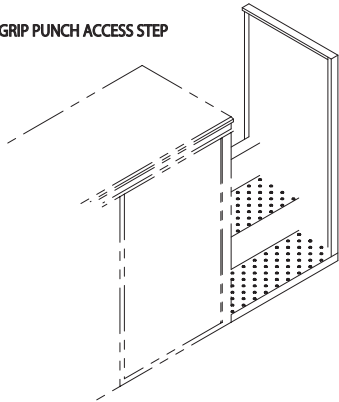

- ACCESS STEP WAY

LOCATION _____

WELDER COMPARTMENT OPTIONS

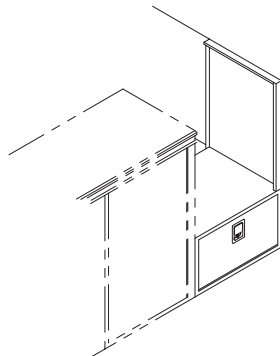

- WELDER STORAGE AREA WITH TOOLBOX

LOCATION _____

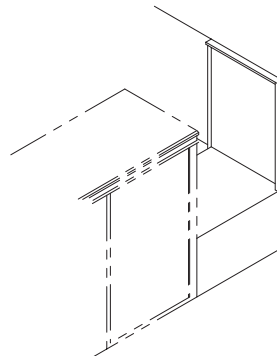

- WELDER STORAGE AREA WITH FILLER PANEL

LOCATION _____

RUBBER FENDER KIT

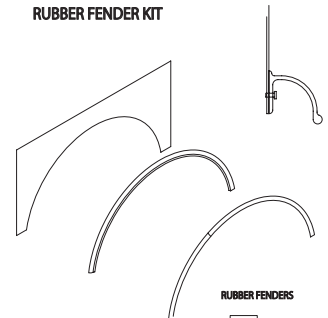

RUBBER FENDERS

- NOT INSTALLED
- INSTALLED

TAILSHELF OPTIONS

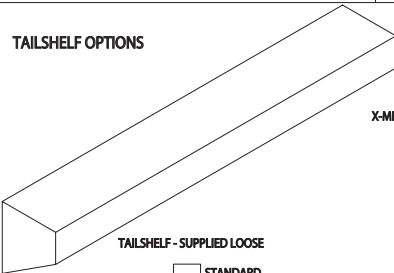

TAILSHELF - SUPPLIED LOOSE

- STANDARD
- WITH THRU-COMPT. (X-MEMBER HEIGHT)
- WITH THRU-COMPT. (SADDLE TYPE)
- WIDTH, 78 1/2 88 1/2 94 1/2
- DEPTH, 12 18 24



X-MEMBER HEIGHT

SADDLE TYPE

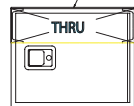

CAB SHIELD

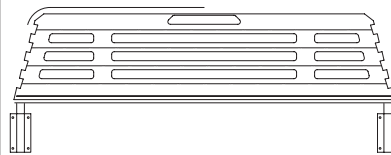

- CABSHIELD - SUPPLIED LOOSE

GRAB HANDLE



GRAB HANDLE

- CHROME FINISH - QUANTITY _____
- ZINC FINISH - QUANTITY _____

GUARD PANEL OPTIONS

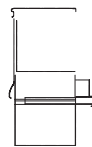
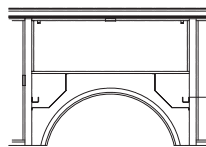
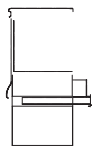
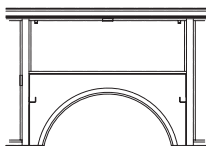

WHEELHOUSING GUARD PANELS

- NOT INSTALLED - QUANTITY _____
- INSTALLED

FUEL HOSE GUARD PANELS

- NOT INSTALLED - QUANTITY _____
- INSTALLED LOCATION _____

WHEEL CHOCK HOLDERS

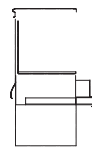
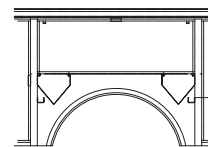

CHOCK BLOCK HOLDERS

- NOT INSTALLED - QUANTITY _____
- INSTALLED LOCATION _____

SALES REP: _____